

Wallpaper Corner Profile 3095, rounded



L-shaped plastic corner profile with rounded edge, for perfect wallpapering on outer corners, for interior use

Field of application

For technically correct, neat formation of the wallpapering on the outer corners, e.g., on exposed windows and door niches, room corners, etc., where there must be flawless continuation of patterns, and where there should also be a neat cut on the corner ending. Due to the rounded edge with a radius of over 2 mm, it is ideally suited for use in public facilities, such as e.g., kindergartens or schools.

Properties

- Made from rigid PVC
- White and silver
- Rounded edge, radius ≥ 2 mm
- Shock-proof
- Stable in shape
- Easy to apply
- For interior use
- Conforms to the accident prevention regulation for kindergartens and schools (GUV-SR S2 and GUV-V S1)

Material description

Color shades	White and silver 0995
Base material	Rigid PVC
Format	L-shaped bracket
Side width	20 mm x 20 mm
Thickness	Approx. 1 mm
Edge	Rounded, radius ≥ 2 mm
Length	2.60 m

Material description

Dimensions

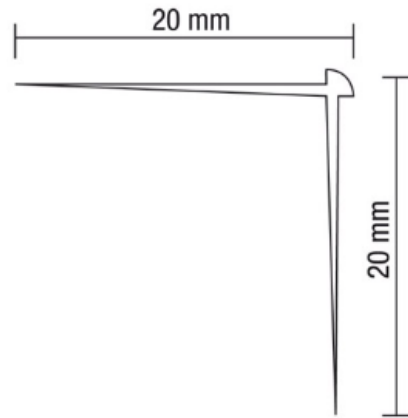

Packaging 15 units/bundle

Use

Bonding Glue the Wallpaper Corner Profile 3095, rounded, with Decorative Profile Adhesive 3041 or for non-adhesive, critical substrates with Pattex Mounting Adhesive 1551. Cover the corner and inner sides of the profile with adhesive. Then put the profile onto the corner and press it down firmly. Fill the leg of the glued wallpaper corner profile with e.g., Briplast Silafill 1886 to prevent lap marks. After the glue has dried, lay the wallpaper over the profile with a small overhang on each side, and use a cutter knife to cut it neatly on each side along the outer edge. The outer corner is now finished and can also resist higher stress to the surface.

Consumption Approx. 1.0 m/meter

Application temperature Do not apply if air or object temperature is below +5°C.

Storage

Store in a cool and dry place.

Coating build-up

Substrate preparation The substrate must be solid, dry, clean, load-bearing, and free from efflorescences, sintered layers, separating agents, corrosion-promoting components, or other intermediate layers affecting the adhesion. Check existing coatings for their suitability, load-bearing capacity, and adhesive properties. Thoroughly remove defective and unsuitable coatings and dispose of them in accordance with the applicable regulations. Thoroughly rinse off reversible, water-sensitive coats (e.g. distemper). Wash down intact coats of oil paints and varnishes with an alkaline solution, sand them well and clean the surface. Remove wall coverings, including remains of paste and paper waste. Treat replastered areas with a fluorine primer in a technically correct manner. Depending on the substrate condition, fill rough surfaces with e.g., Briplast Silafill 1886. Pretreat the substrate in accordance with the requirements. See also VOB Part C, DIN 18363, Section 3.

Bonding Glue the Wallpaper Corner Profile 3095, rounded with Decorative Profile Adhesive 3041 or Pattex Mounting Adhesive 1551.

Wallpapering After the glue and filling have dried, apply the selected wall covering.

Notes

Further information Follow the instructions in the data sheets of the products used.

Remark

This Data Sheet is based on extensive development work and years of practical experience. The translation corresponds to the current German version, in compliance with the German laws, regulations, standards and guidelines. Its content does not constitute a contractual legal relationship. The user/buyer is not released from the responsibility of checking our products to ensure they are suitable for the intended application. In addition, our general terms of business apply.

When a new version of this Data Sheet with updated information is published, the previous version no longer applies. The current version is available on our website.

Brillux
Weseler Straße 401
48163 Münster
GERMANY
Phone +49 251 7188-0
Fax +49 251 7188-105
info@brillux.de
www.brillux.com